



## Mechanical Seal HBAF-HBAP

### Operating range

Shaft diameter:  $d_1 = 120 \dots 250 \text{ mm}$  (4.72" ... 9.84")

Pressure:  $p_1 = 50 \text{ bar}$  (725 PSI)

Temperature:  $t = +300 \text{ }^\circ\text{C}$  (+572  $^\circ\text{F}$ )

Sliding velocity:  $v_g = 65 \text{ m/s}$  (213 ft/s)

Axial movement:  $\pm 3 \text{ mm}$

### Materials

- Seal face: Silicon carbide (Q), SiC-C-Si Silicon impregnated carbon (Q3)
- Seat: Carbon graphite resin impregnated (B), SiC-C-Si Silicon impregnated carbon (Q3)
- Secondary seals: EPDM (E), FFKM (K)
- Springs: CrNiMo steel (G)
- Metal parts: CrNiMo steel (G)

### Features

- Cartridge design
- Single seal
- Balanced
- Dependent on direction of rotation
- Integrated pumping device
- Stationary spring loaded unit
- Inserted seal face
- Rotating carbon seat

### Advantages

- Deformation-optimized seal for high sliding velocities and medium pressures
- Economical due to standardized inner components
- High flexibility due to adaptation of the connection parts to the pump seal chamber
- Optimum heat dissipation due to integrated pumping device and optimized seat / seal face design
- Insensitive to shaft deflections due to stationary design
- Pre-assembled unit for quick and easy installation
- Only small number of components

### Recommended applications

- Power plant technology
- Oil and gas industry
- Refining technology
- Petrochemical industry
- Chemical industry
- Boiler feed water with low conductivity
- Boiler feed pumps

# HBrinker Mechanical Seal

Engineered seals Mechanical Seal HBAF-HBAP

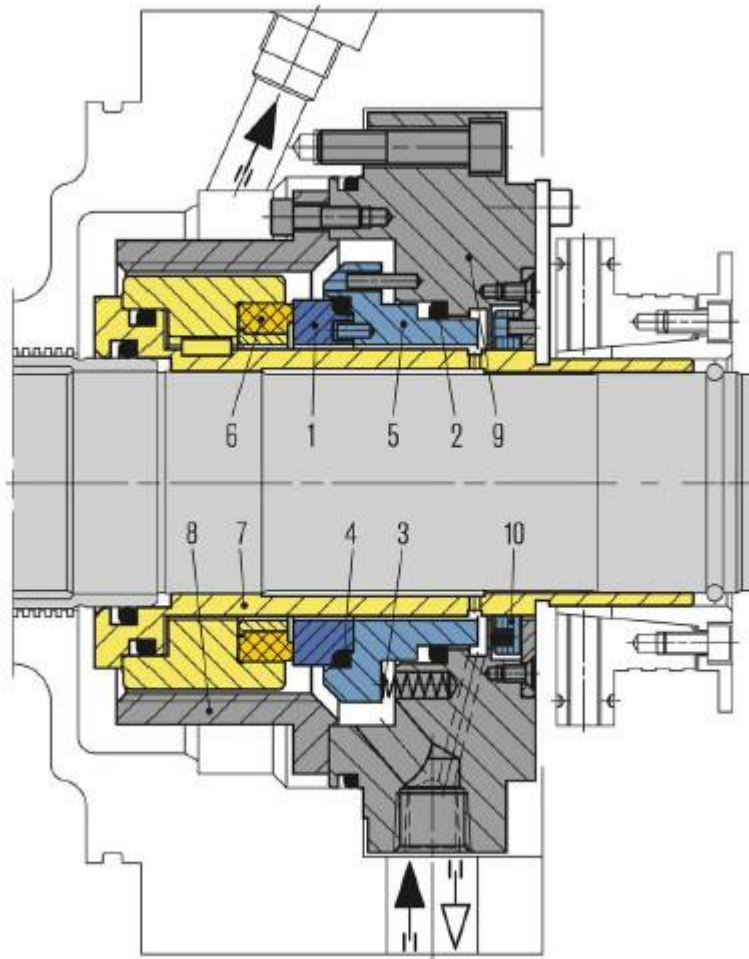

Item	Description
1	Seal Face
2	O-Ring
3	Spring
4	O-ring
5	Seat Collar
6	Seat
7	Shaft Sleeve
8	Pumping Sleeve
9	Cover
10	Throttle ring

# HBrinker Mechanical Seal



v

