



TYPE 1/1B

ELASTOMER BELLOWS SEALS

Technical Specification

- A - Face/Primary Ring
- B - Spring
- C - Elastomer Bellows
- D - Retainer
- E - Drive Band
- F - Spring Holder
- G - Disc

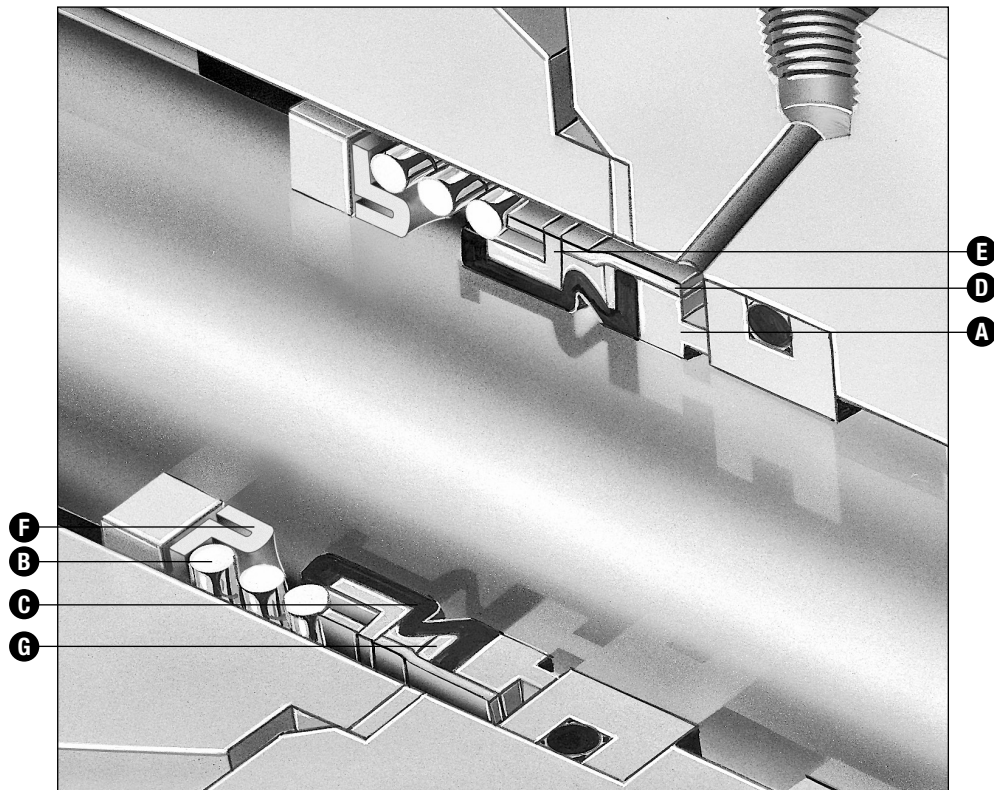

Product Description

John Crane's Type 1 elastomer bellows seal is widely recognized as the industry workhorse with a proven track record of exceptional performance. The Type 1 is suitable for a wide range of service conditions from water and steam to chemicals and corrosive materials.

- For use in pumps, mixers, blenders, agitators, refrigeration compressors, blowers, fans and other rotary shaft equipment
- For pulp and paper, petrochemical, food processing, wastewater treatment, chemical processing, power generation and other demanding applications

Design Features

- Mechanical drive — eliminates overstressing of bellows
- Self-aligning capability — automatic adjustment compensates for abnormal shaft end play runout, primary ring wear and equipment tolerances
- Special balancing — for higher pressure applications and less wear
- Non-clogging, single-coil spring — not affected by buildup of solids
- Low drive torque — improves performance and reliability

Performance Capabilities

- Temperature: -40°C to 205°C/-40°F to 400°F (depending on materials used)
- Pressure: 1: up to 29 bar g/425 psig
1B: up to 82 bar g/1200 psig
- Speed: See enclosed speed limits chart.



TYPE 1/1B

ELASTOMER BELLOWS SEALS

Technical Specification

Type 1 Typical Arrangement

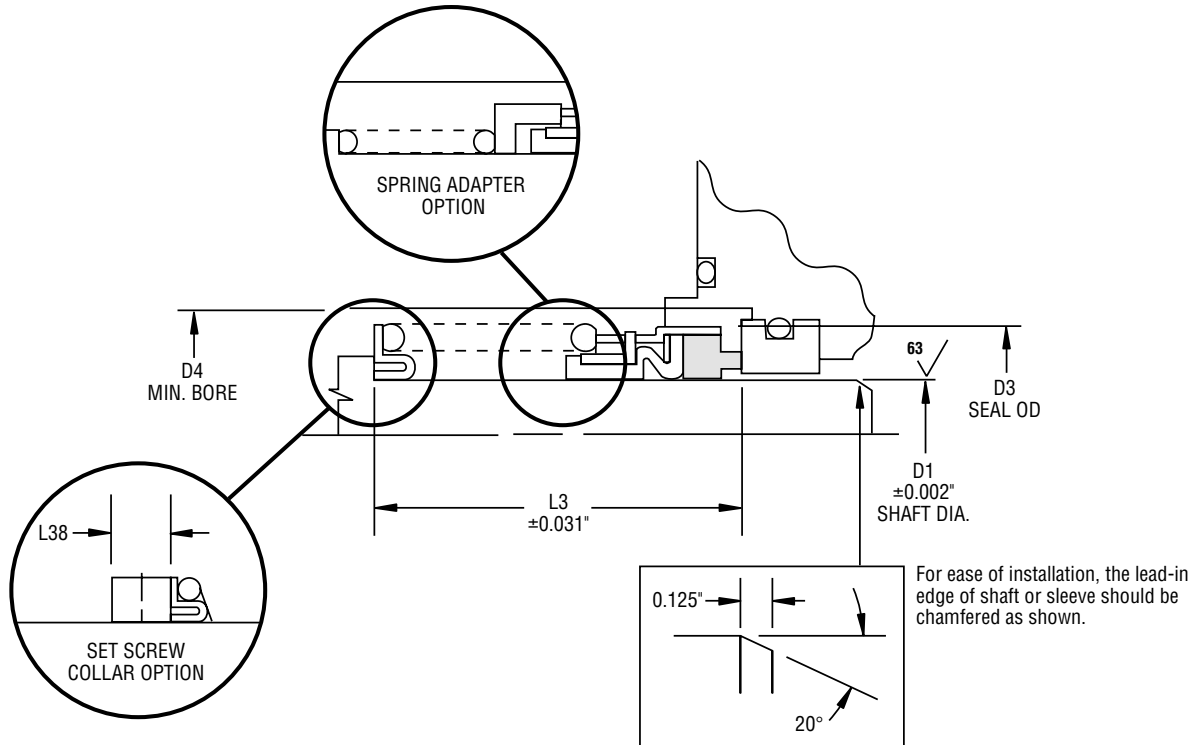

Type 1 Dimensional Data (inches)

Seal Size/D1 (inches)	D3	D4	L3	L38
1.000	1.500	1.750	1.562	0.375
1.125	1.625	1.875	1.625	0.375
1.250	1.812	2.000	1.625	0.375
1.375	1.875	2.125	1.687	0.375
1.500	2.000	2.250	1.687	0.375
1.625	2.250	2.500	2.000	0.375
1.750	2.375	2.625	2.000	0.375
1.875	2.500	2.750	2.125	0.375
2.000	2.625	2.937	2.125	0.375
2.125	2.812	3.125	2.375	0.500
2.250	2.937	3.250	2.375	0.500
2.375	3.062	3.375	2.500	0.500
2.500	3.187	3.500	2.500	0.500
2.625	3.375	3.750	2.750	0.500
2.750	3.500	3.875	2.750	0.500
2.875	3.625	4.000	2.875	0.500
3.000	3.750	4.187	2.875	0.500
3.125	4.000	4.437	3.125	0.500
3.250	4.125	4.562	3.125	0.500
3.375	4.250	4.687	3.125	0.500
3.500	4.375	4.812	3.125	0.500
3.625	4.500	4.937	3.250	0.562
3.750	4.625	5.062	3.250	0.562
3.875	4.750	5.187	3.375	0.562
4.000	4.875	5.312	3.375	0.562



TYPE 1/1B

ELASTOMER BELLOWS SEALS

Technical Specification

Type 1B Typical Arrangement

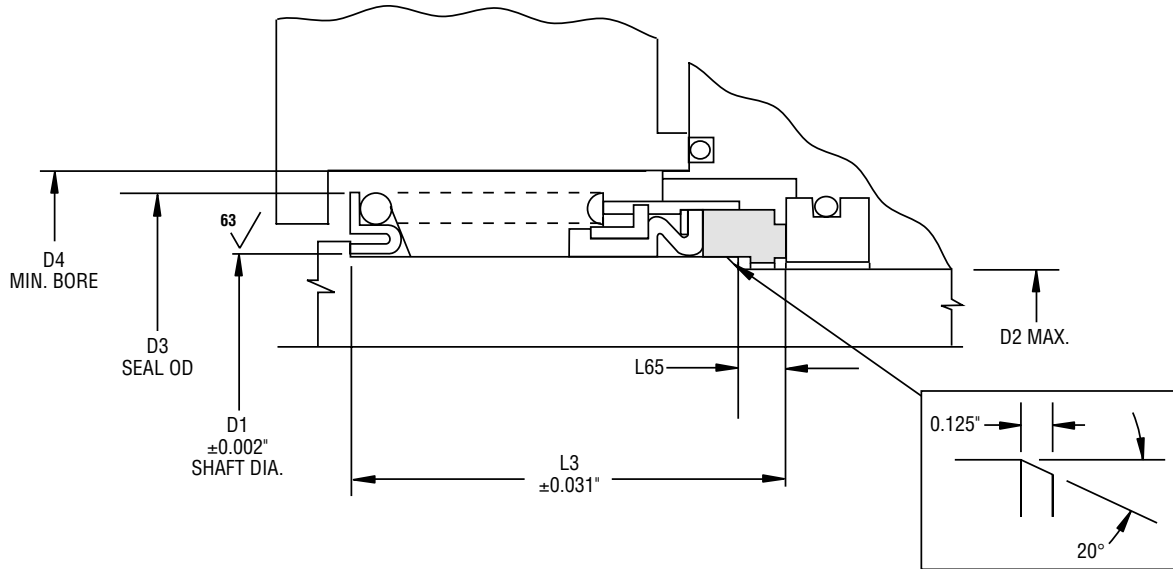

For ease of installation, the lead-in edge of shaft or sleeve should be chamfered as shown.

Type 1B Dimensional Data (inches)

Seal Size/D1 (inches)	D2	D3	D4	L3	L65
1.000	0.875	1.500	1.750	1.875	0.343
1.125	1.000	1.625	1.875	1.937	0.343
1.250	1.125	1.812	2.062	1.937	0.343
1.375	1.250	1.875	2.125	2.000	0.343
1.500	1.375	2.000	2.250	2.000	0.343
1.625	1.500	2.250	2.500	2.375	0.437
1.750	1.625	2.375	2.625	2.375	0.437
1.875	1.750	2.500	2.750	2.500	0.437
2.000	1.875	2.625	2.937	2.500	0.437
2.125	2.000	2.812	3.125	2.750	0.500
2.250	2.125	2.937	3.250	2.750	0.500
2.375	2.250	3.062	3.375	2.875	0.500
2.500	2.375	3.187	3.500	2.875	0.500
2.625	2.500	3.375	3.750	3.125	0.562
2.750	2.625	3.500	3.875	3.125	0.562
2.875	2.750	3.625	4.000	3.250	0.562
3.000	2.875	3.750	4.187	3.250	0.562
3.125	2.875	4.000	4.437	3.500	0.625
3.250	3.000	4.125	4.562	3.500	0.625
3.375	3.125	4.250	4.687	3.500	0.625
3.500	3.250	4.375	4.812	3.500	0.625
3.625	3.375	4.500	4.937	3.625	0.625
3.750	3.500	4.625	5.062	3.625	0.625
3.875	3.750	4.750	5.187	3.750	0.625
4.000	3.875	4.875	5.312	3.750	0.625



TYPE 1/1B

ELASTOMER BELLOWS SEALS

Technical Specification

Basic Pressure Rating

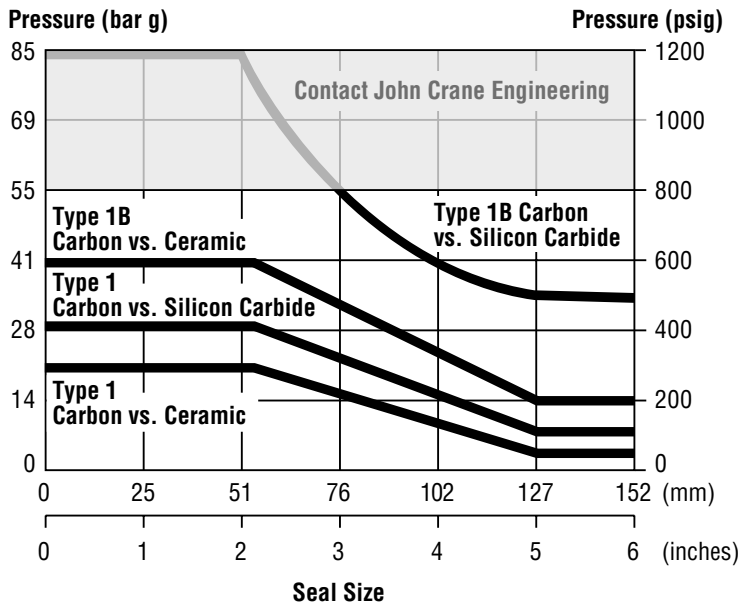

To determine the maximum pressure for the Type 1 or 1B required, multiply the maximum pressure by the multiplier factors to obtain the maximum operating pressure.

The basic pressure rating is based on a standard Type 1 or Type 1B seal installed according to the criteria given in this data sheet and according to generally accepted industrial practices. The basic pressure rating assumes stable operation at 1800 rpm in a clean, cool, lubricating, nonvolatile liquid, with an adequate flush rate. When used with the multiplier factors, the basic pressure rating can provide a conservative estimate of the dynamic pressure rating.

Contact John Crane for process services outside this range and with more detailed application information in order to obtain the actual dynamic pressure rating.

Multiplier Factors

	Selection Considerations	Multiplier Factor
Speed	1800 rpm Above 1800 rpm	x 1.00 *
Sealed Fluid Lubricity	Petrol/Gasoline, Kerosene, or Better Water and Aqueous Solutions Flashing Hydrocarbons** (Specific Gravity <0.65)	x 1.00 x 0.75 x 0.60
Sealed Fluid Temperature (for carbon only)	Below 79°C/175°F From 79°C to 121°C/175°F to 250°F From 121°C to 177°C/250°F to 350°F Above 177°C/350°F	x 1.00 x 0.90 x 0.80 x 0.65

* Multiplier = 1800/new speed Example: If new speed = 2700 rpm
Multiplier = 1800/2700 = 0.67

** The ratio of sealed pressure to vapor pressure must be greater than 1.5, otherwise consult John Crane. If the specific gravity is less than 0.60, consult John Crane.

Example for Determining Pressure Rating Limits

Seal: 76mm/3" diameter Type 1B

Product: Water

Face material: carbon vs. silicon carbide

Temperature: 16°C/60°F

Shaft Speed: 1800 rpm

Using the basic pressure rating chart, the maximum pressure would be 55 bar g/800 psig.

From the multiplier factors chart, apply the multipliers for the specific service requirements to determine the maximum dynamic pressure rating for the application.

55 bar g/800 psig x 1 x 0.75 x 1 = 41 bar g/600 psig

At 1800 rpm with the service conditions noted, a 76mm/3" diameter Type 1B seal has a dynamic pressure rating of 41 bar g/600 psig. If operating pressure exceeds this dynamic rating, consult your John Crane representative.



TYPE 1/1B

ELASTOMER BELLOWS SEALS

Technical Specification

Breakout (Starting) Torque Consumption for Seal

For starting torque power consumption, consult John Crane.

Hydrostatic Pressure Limits

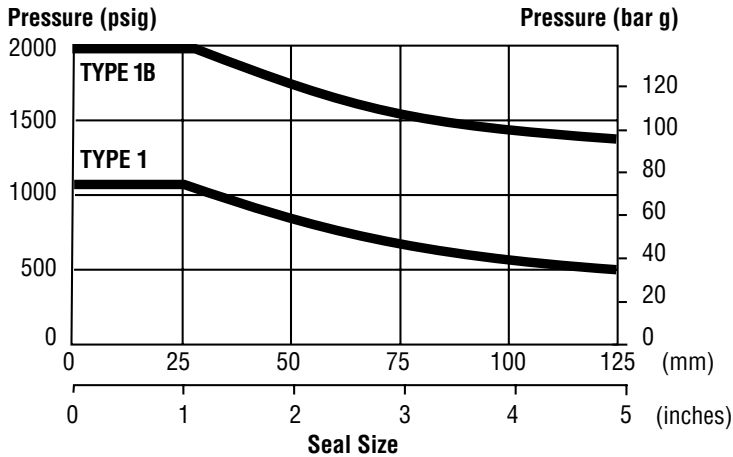

Speed Limits for Coil Springs

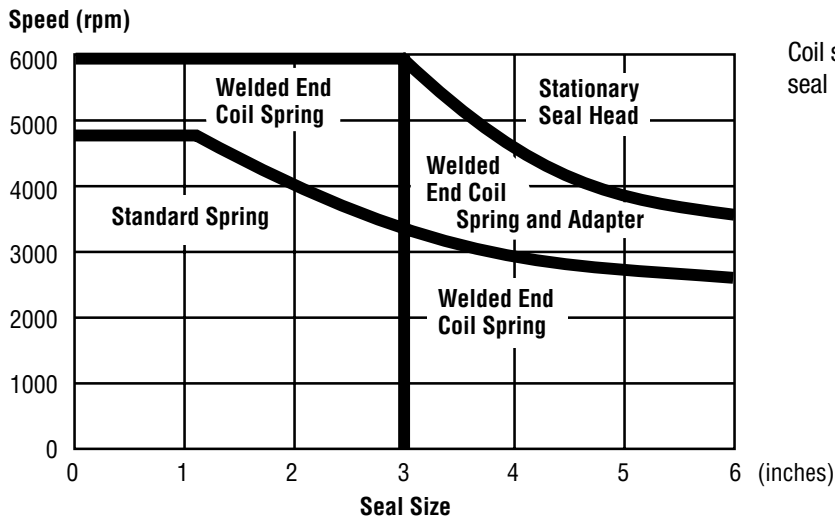

Coil spring requirements for rotating Type 1 and 1B seal heads with standard stuffing box diameter.

Criteria for Installation

Shaft/Sleeve	Limits
Surface Finish	1.00" to 3.125" dia./63 Ra 3.125" dia. and up/32 Ra
Ovality/Out of Roundness (Shaft)	0.051mm/0.002"
End Play/Axial Float Allowance	±0.13mm/0.005"